



STAINLESS STEEL CENTRIFUGAL PUMP

Model

SCM-ST Series



SCM-34ST

SCM-18ST

CONSTRUCTION:

PUMP Centrifugal

Pump Body: Stainless Steel

Impeller: Stainless Steel

Mechanical Seal: Carbon / Ceramic / Stainless steel

MOTOR Single Phase Heavy Duty Continuous Work

Motor Housing: Aluminium

Shaft: Stainless Steel

Insulation: Class B / Class F

Protection: IP44 / IP54

Cooling: External ventilation

SCM-ST series STAINLESS STEEL centrifugal pumps are single stage, high efficient electric pumps, consists of a miniature motor and a single impeller centrifugal pump.

The pump and the impeller are made of stainless steel, make it better and ideal for pumping drinking water.

They have a good performance in Big Capacity and High Head.

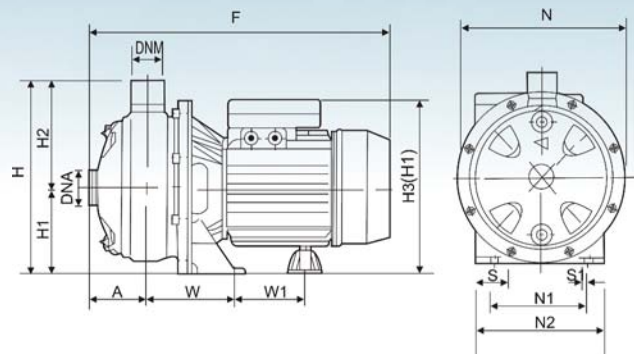
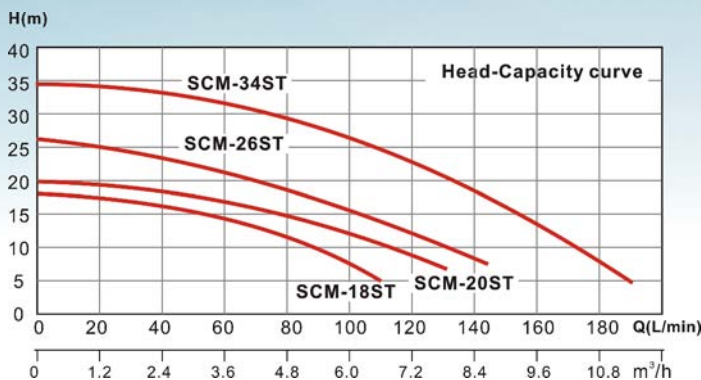

PERFORMANCE SPECIFICATIONS

Model	Power		Ampere 220V/50Hz	Suct.max m	Q=capacity													
	HP	KW			m ³ /h	0	1.2	2.4	3.6	4.8	5.4	6.6	7.2	7.8	8.7	9.6	11	11.4
					H (m)													
SCM-18ST	0.5	0.37	2.5	9	18	16	15	14	12	10	5	-	-	-	-	-	-	-
SCM-20ST	0.75	0.55	3.8		20	19	18	17	16	15	12	10	7	-	-	-	-	-
SCM-26ST	1	0.75	5.2		26	25	24	22.5	21	20	17	15	12	8	-	-	-	-
SCM-34ST	1.5	1.1	7		34	33	32	31	30	29	27	25	23	19	14	10	5	-

*110V, 110/220V, 60Hz etc. models are available on request.

OVERALL & INSTALLATION DIMENSIONS

Model	DIMENSIONS (mm)														PACKAGE DIMENSIONS & G.W.			
	DNA	DNM	A	F	H	H1	H2	N	N1	N2	W	W1	S	S1	I	M	L	KG
SCM-18ST	1.25"	1"	52	315	232	108	124	120	213	158	92	82	39	9	390	220	270	12
SCM-20ST	1.25"	1"	52	315	232	108	124	120	213	158	92	82	39	9	390	220	270	12.5
SCM-26ST	1.25"	1"	52	315	232	108	124	120	213	158	92	82	39	9	390	220	270	13.5
SCM-34ST	1.25"	1"	52	365	257	120	137	140	240	180	92	82	39	9	400	260	330	24

